

# DYNAMIC GROUP / TETTO SERIES

## DGTS 201-P



**CMR PLAY**

**Product Information**

Dimensions (W x L x H)	: 19'4" x 17'5" x 15'8"
Age Group	: 5-12
Capacity	: 18
Fall Height	: 6'9"
Safety Area	: 614 ft <sup>2</sup>



# DYNAMIC GROUP / TETTO SERIES

Tetto is a series of play units with an abstract theme that feels like both old and new homes. With the asymmetrical roofs and windows, contrast and vibrant colours, it is aimed to stretch children's imagination. Different floors and platform heights in this series help create games in every corner of the product. Climbing stations, rope crossings, slides and panel games are used in order to make play more active. The climbing systems in this series aim to strengthen muscles as well as improve coordination skills.

# DYNAMIC GROUP / TETTO SERIES

## DGTS 201-P



**Metal parts are comprised of ST 37 Steel with a 3-step metal finish. Sandblasting and solvent-free zinc primer coating and electrostatic powder paint application is inherently corrosion resistant under extreme weather conditions and UV.**



**Single-casing aluminum cast connectors are compressed with 300 tons to avoid moving and premature wear. Ball knot "connector" is shapely and pleasant to grip with no sharp angles or edges.**



**Sliding surface of the equipment is made of UV resistant High Density Polyethylene Sheet which is an alternative to stainless steel slides in sunny environments. Sides of the slide is HPL or HDPE with rounded edges.**



**CmrRope™ is formed by 6 strands of galvanized wires and a core either steel or fiber. Each strand is tightly braided with Polyester which is adhered to galvanized wires with a patented method to create a solid surface where polyester meets with wires. So extra protection is achieved against friction and vandalism. Surface is extremely abrasion and UV resistant also fire retardant.**



**High quality panels made of HPL panels are milled to provide a smooth, gently rounded edge. The thickness of the panels varies according to its purpose for floors, roofs, and walls. These panels are connected to steel pipes or profiles with cast aluminum panel clamps or flanges.**



DYNAMIC GROUP / **TETTO SERIES**  
 DGTS 201-P

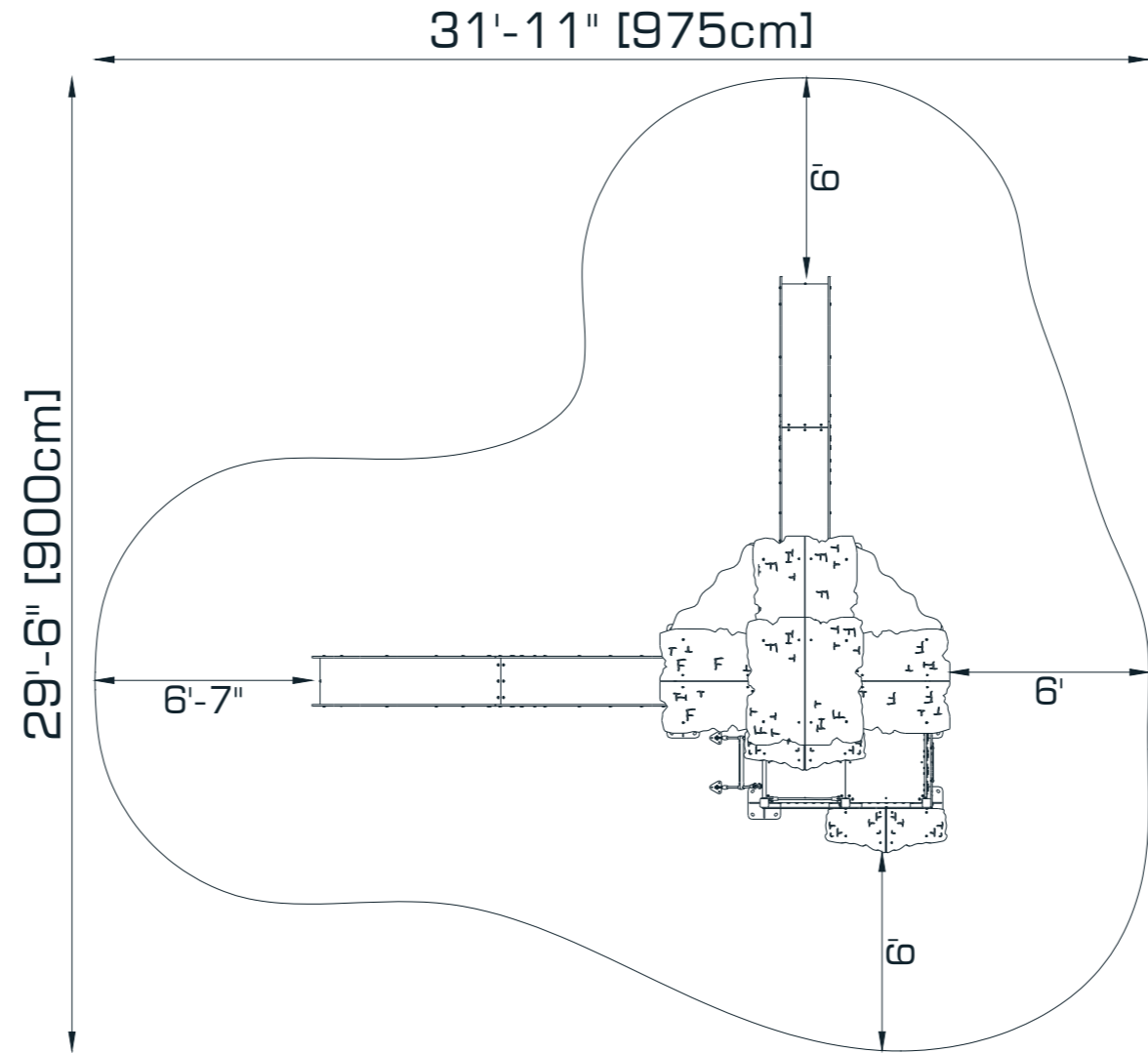

**TOP VIEW**

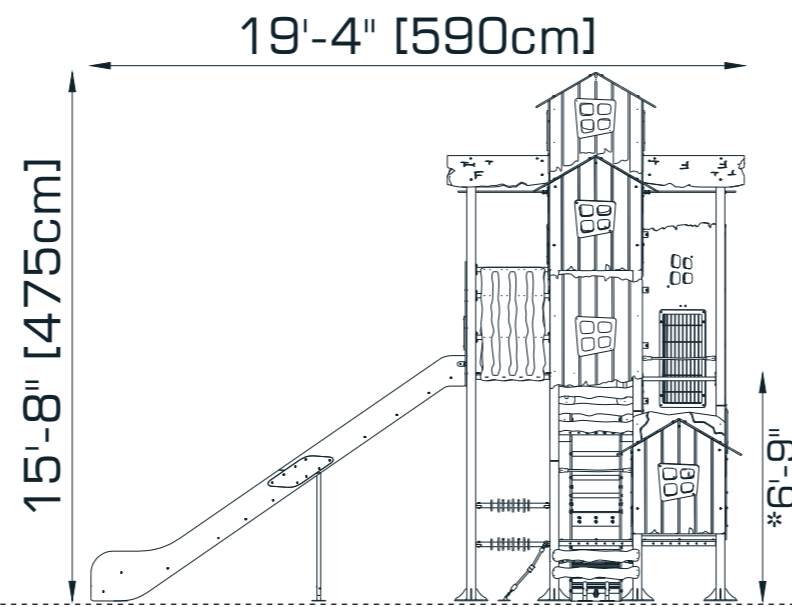

**FRONT VIEW**

\*Maximum Fall Height

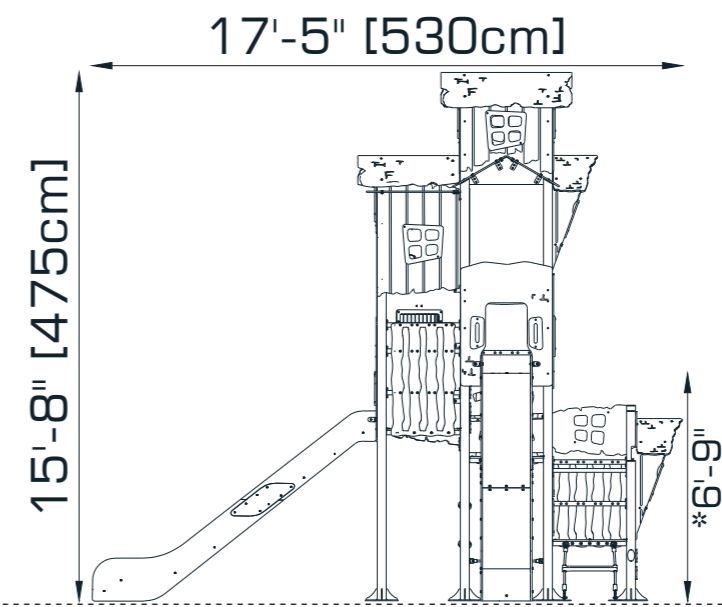

**SIDE VIEW**

# DYNAMIC GROUP / TETTO SERIES

## DGTS 201-P



**BOUNCING**

To bounce is the act of bouncing on a responsive, flexible, elastic or tensile surface.



**SLIDE**

To slide is the act of moving fast downwards steady on a slide.



**BALANCE**

To balance is to stay upright when walking or standing on a surface that makes this challenging.



**ROCK**

To rock is the action of rocking back and forth, or sideways, on e.g. a piece of spring equipment.



**OTURMA / SITTING**

It is an area where children can rest while sitting and have fun.



**SWING**

To swing is the movement of swinging back forth, of in circular movement, seated, standing or lying, in a unhindered arc.



**HANGING**

To hang in arms is the act of carrying the body with the hands or arms, possible to traverse to another platform or play item.



**SPIN**

To spin involves a fast, repeating horizontal or vertical turn of the body on a piece of equipment that facilitates social interaction.



**CLIMBING**

To climb is the act of moving upwards, cross coordinating arms and legs, on a vertical or inclined surface or net.



**CRAWLING**

To crawl is the movement of moving forwards or backwards, cross-coordinating arms and legs, on a horizontal or slightly incline surface



**RUNNING**

Running is an activity that encourages children to interact with the playgroup by running and develop physically.



**ACCESSIBLE**

These are special areas where children with disabilities can play and have fun and without feeling different.



**INTERACTION**

It is children's communicating with the play group by touching and feeling.



**ROTATE**

To rotate involves a vertical or horizontal slower paced turn of the body, facilitated by a piece of equipment.



**EQUALITY**

Equality is the feature of the playgroup to attract the attention of all children, regardless of gender.



**SOCIALIZE**

To socialize is the act of meeting, communicating or cooperating in an activity that stimulates and facilitates social interaction.



**ROLE PLAY**

Role play is motivated through play items that stage a frame, place or environment for acting out make believe or role play scenarios.



**PULL**

To pull is the act of pulling item towards you or you towards an item with one or both hands, or possibly with the entire body.



**GLIDE**

To glide is the act of moving from one point to another without shifting the feet, in a horizontal or vertical movement in a seated, lying or standing position, letting gravity do the work.



**PUSH**

To push is the act of pushing an item away from you with one or both hands, possibly with the entire body.