

ACCESSORIES / SWING

CA 178



Product Information

Dimensions (W x L x H)	: 14'4" x 4'10" x 7'3"
Age Group	: 2-12
Capacity	: 2
Fall Height	: 4'9"
Safety Area	: 531 ft ²

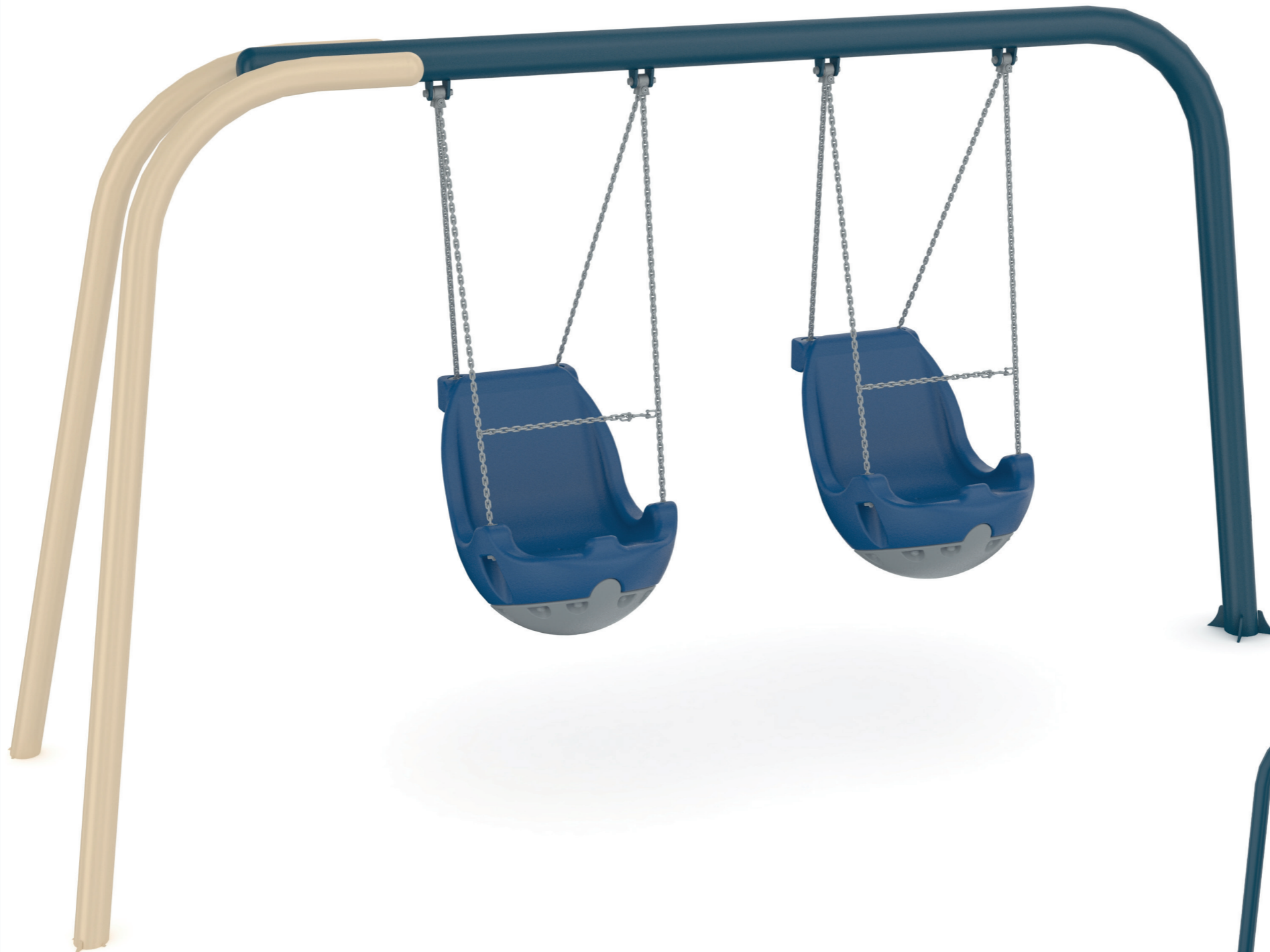

SWING

Swings are swing units that enable children to gain spatial awareness at a young age, which enhances their perception of gravity and perspective. It is aimed that all children discover the swinging experience with singular use & combined use swings, and swings that are specially designed for the disabled.

ACCESSORIES / SWING CA 178



Metal parts are comprised of ST 37 Steel with a 3-step metal finish. Sandblasting and solvent-free zinc primer coating and electrostatic powder paint application is inherently corrosion resistant under extreme weather conditions and UV.



Robot joint is a custom-designed high durability swing joint that also eliminates any finger entrapment issue. The swing upper joint mechanism was produced with the precision casting technique. Between the two ears welded on the swing carrier pipe, rigid bedding to be fixed with M12x80 bolts and a Teflon bearing should be used to prevent abrasions.



The disabled swing seat is designed and produced in a way that includes a railing against falls so it gives the opportunity to kids with disabilities to play on as well as other minors. Chain bearings should be designed to prevent the chain from finger entrapment. All connection details should be concealed with plastic caps made of PA6 material with injection technique.

Engelli salıncak koltuğu, düşmeye karşı korkuluk içerecek şekilde tasarlanmış ve üretilmiştir, böylece engelli çocuklara ve diğer küçüklere oynama fırsatı verir. Zincir yatakları, parmak sıkışmasını önleyecek şekilde tasarlanmıştır. Tüm bağlantı detayları enjeksiyon tekniği ile PA6 malzemedeki yapılmış plastik kapaklar ile gizlenmiştir.

ACCESSORIES / SWING
CA 178

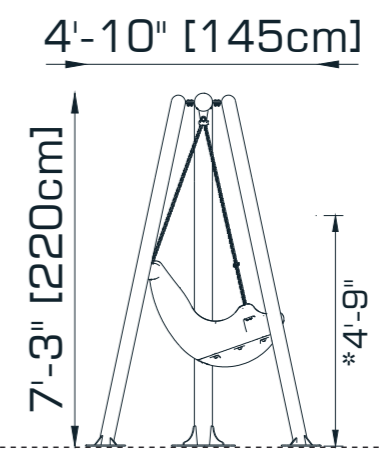
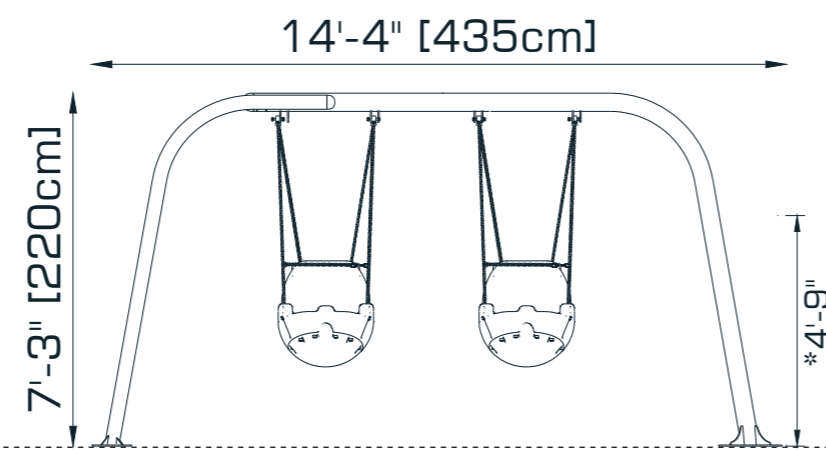
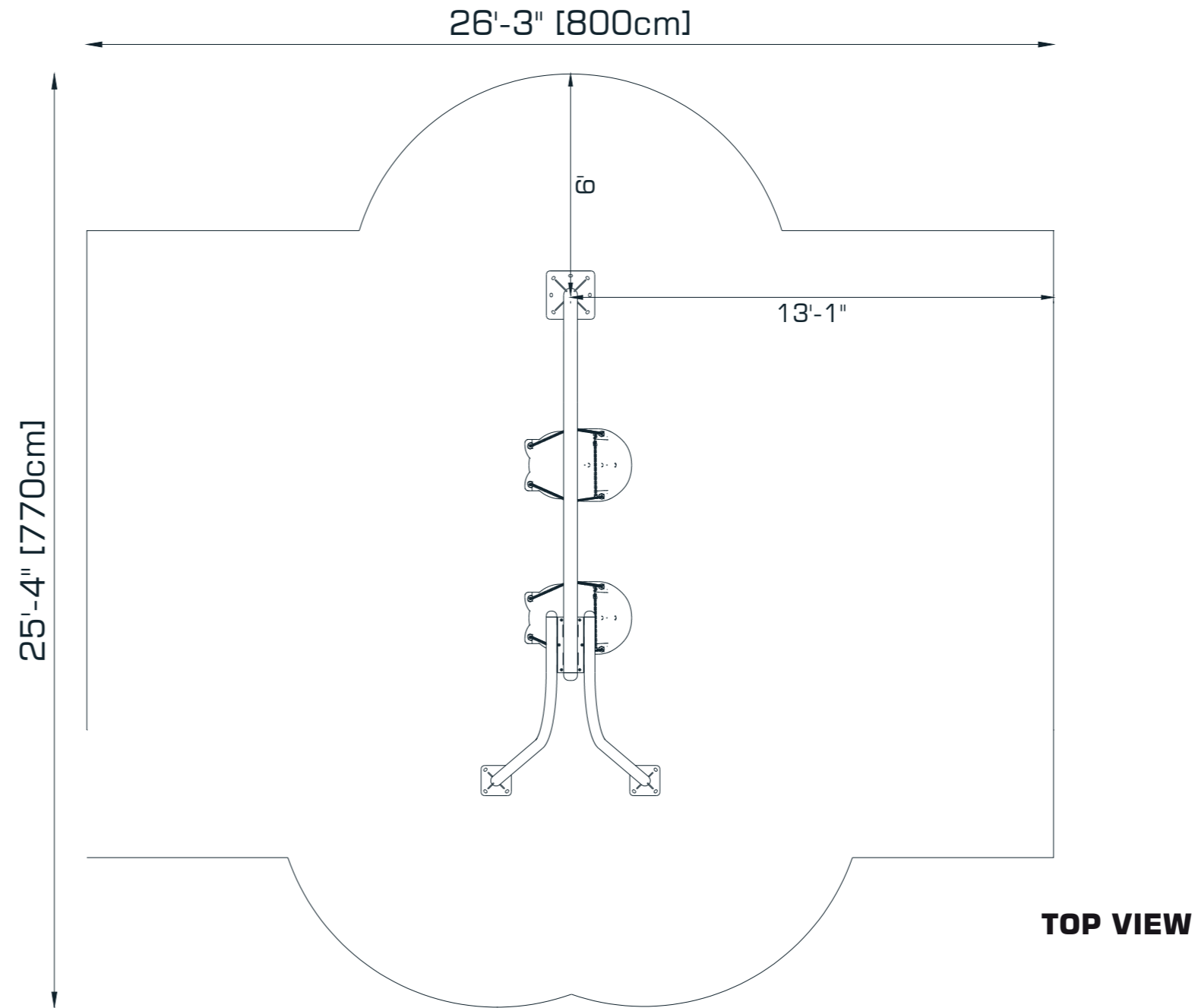

FRONT VIEW
*Maximum Fall Height

ACCESSORIES / SWING

CA 178



BOUNCING

To bounce is the act of bouncing on a responsive, flexible, elastic or tensile surface.



SLIDE

To slide is the act of moving fast downwards steady on a slide.



BALANCE

To balance is to stay upright when walking or standing on a surface that makes this challenging.



ROCK

To rock is the action of rocking back and forth, or sideways, on e.g. a piece of spring equipment.



OTURMA / SITTING

It is an area where children can rest while sitting and have fun.



SWING

To swing is the movement of swinging back forth, of in circular movement, seated, standing or lying, in a unhindered arc.



HANGING

To hang in arms is the act of carrying the body with the hands or arms, possible to traverse to another platform or play item.



SPIN

To spin involves a fast, repeating horizontal or vertical turn of the body on a piece of equipment that facilitates social interaction.



CLIMBING

To climb is the act of moving upwards, cross coordinating arms and legs, on a vertical or inclined surface or net.



CRAWLING

To crawl is the movement of moving forwards or backwards, cross - coordinating arms and legs, on a horizontal or slightly incline surface



RUNNING

Running is an activity that encourages children to interact with the playgroup by running and develop physically.



ACCESSIBLE

These are special areas where children with disabilities can play and have fun and without feeling different.



INTERACTION

It is children's communicating with the play group by touching and feeling.



ROTATE

To rotate involves a vertical or horizontal slower paced turn of the body, facilitated by a piece of equipment.



EQUALITY

Equality is the feature of the playgroup to attract the attention of all children, regardless of gender.



SOCIALIZE

To socialize is the act of meeting, communicating or cooperating in an activity that stimulates and facilitates social interaction.



ROLE PLAY

Role play is motivated through play items that stage a frame, place or environment for acting out make believe or role play scenarios.



PULL

To pull is the act of pulling item towards you or you towards an item with one or both hands, or possibly with the entire body.



GLIDE

To glide is the act of moving from one point to another without shifting the feet, in a horizontal or vertical movement in a seated, lying or standing position, letting gravity do the work.



PUSH

To push is the act of pushing an item away from you with one or both hands, possibly with the entire body.