

X- ERGONOM FITNESS

ACT 303



CMR ACTIVE®

Ürün Bilgisi / Product Information

Boyutlar / Dimensions (LxWxH) : 1,55 x 0,3 x 1,7m

Yaş Grubu / Age Group : ≥140 cm

Kapasitesi / Capacity : 1

Çalışma Alanı / Training Area : 3,1 m²

Güvenlik Alanı / Safety Area : 12,1 m²



Isınma / Warm-up



X - ERGONOM FITNESS / SENIOR FITNESS

İleri Yaş Fitness ürünleri, yaş ilerledikçe azalan hareket yetilerinin tekrar güçlenmesini sağlamak ve ileri yaşta da hem fiziksel hem mental anlamda fit kalabilmeye yardımcı olmaktadır. Ürünler, ileri yaşta kişilerin kullanımına uygun olarak tasarlanmış olup; günlük hayattaki hareketlerin egzersiz haline getirilmesi aracılığıyla fitness deneyimi sunmaktadır. İleri Yaş Fitness ürün grubu, kullanıcıların açık havada egzersiz yaparak fiziksel ve mental olarak dinç kalabilmelerini sağlamaktadır.

Senior Fitness products help users to prevent the gradual decline in the basic movement skills of those who want to stay fit mentally and physically. With seniors in mind, the products are designed which means the possible movements on a daily basis are taken into account. Senior fitness products offer an outdoor workout while helping users to be fit mentally and physically.

X- ERGONOM FITNESS

ACT 303



Metal parts are comprised of ST 37 Steel with a 3-step metal finish. Sandblasting and solvent-free zinc primer coating and electrostatic powder paint application is inherently corrosion resistant under extreme weather conditions and UV.

Metal parçalar, 3 aşamalı metal kaplamalı ST 37 çelikten oluşur. Kumlama ve solvent içermeyen çinko astar kaplama ve elektrostatik toz boya uygulaması, aşırı hava koşulları ve UV altında olarak korozyona dayanıklıdır.



Exercise panels are made of 12mm HPL panels with high UV resistant and fire retardant. To increase exercise comfort, HPL minimize the generation of electrostatic charge by contact-separation or rubbing with another material.

12mm HPL plakadan imal edilen egzersiz panelleri; yüksek UV dayanımına ve alev geciktirme özelliğine sahiptir. HPL malzeme; temas ve sürtünme ile oluşan elektrostatik yükü en aza indirerek antrenman konforunu yükseltir.



Polyethylene injection molded anchorage covers are used to seal the metal anchors and provide a nicer look.

Enjeksiyon kalıp tekniğiyle polietilen malzemeden üretilen ankraj kapakları ile metal ayaklar kapatılmakta ve tasarımı tamamlanmaktadır.



X- ERGONOM FITNESS

ACT 303

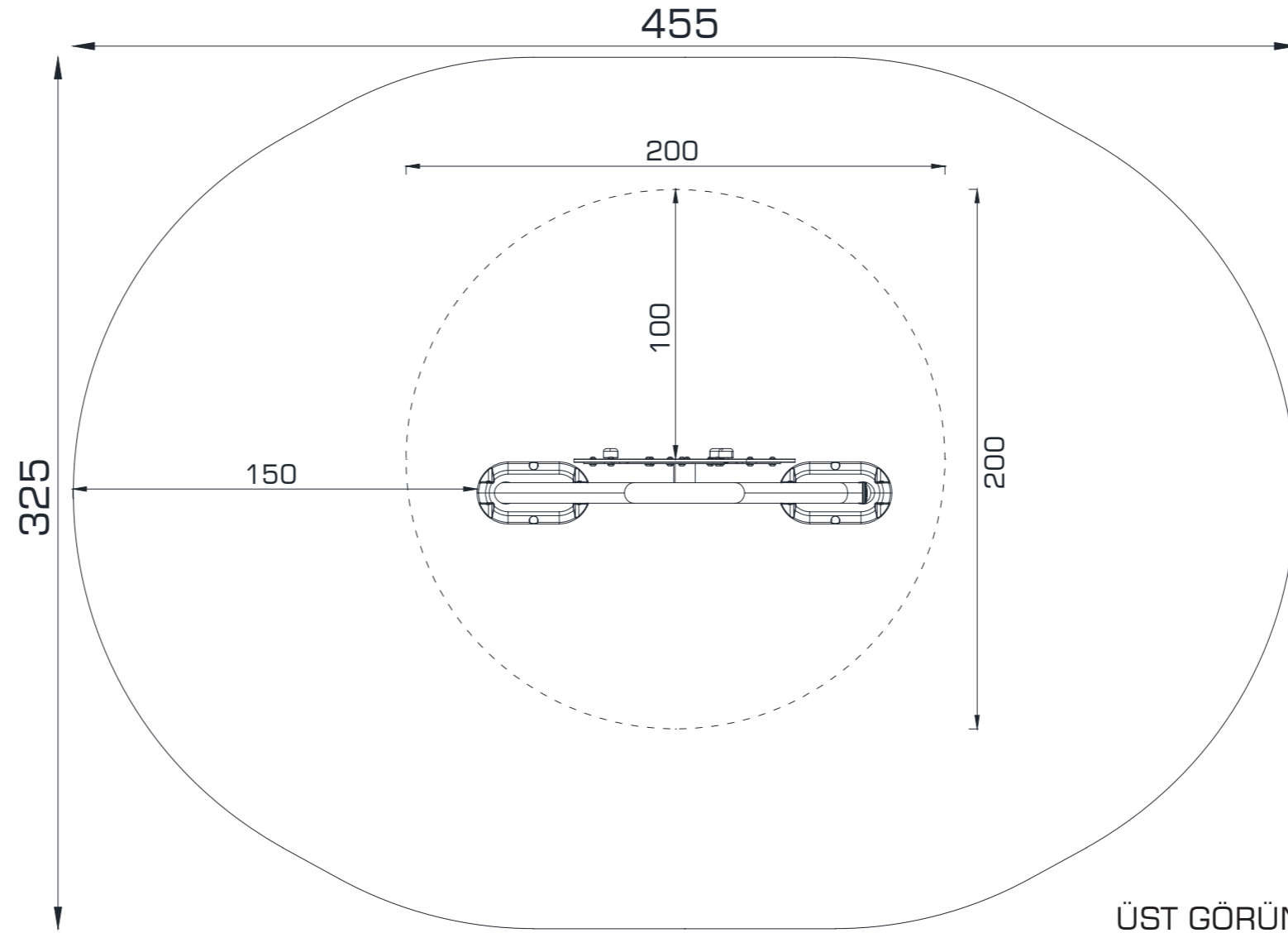

ÜST GÖRÜNÜŞ / **TOP VIEW**

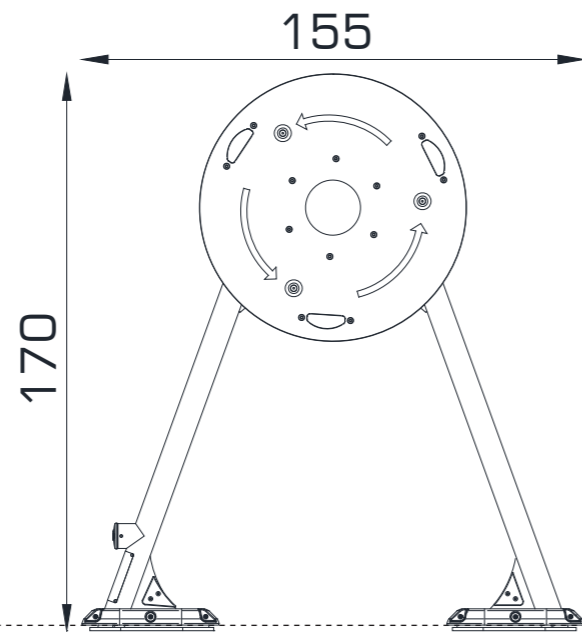

ÖN GÖRÜNÜŞ / **FRONT VIEW**

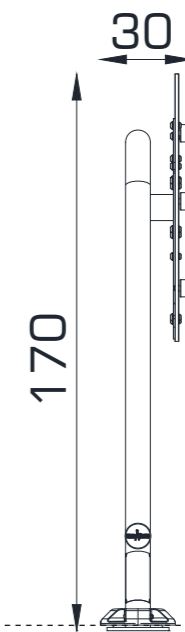

YAN GÖRÜNÜŞ / **SIDE VIEW**

*Maksimum Düşme Yüksekliği / **Maximum Fall Height** Gösterilen ölçüler cm cinsindedir / **Dimensions shown are in cm**

YARARLARI / BENEFITS

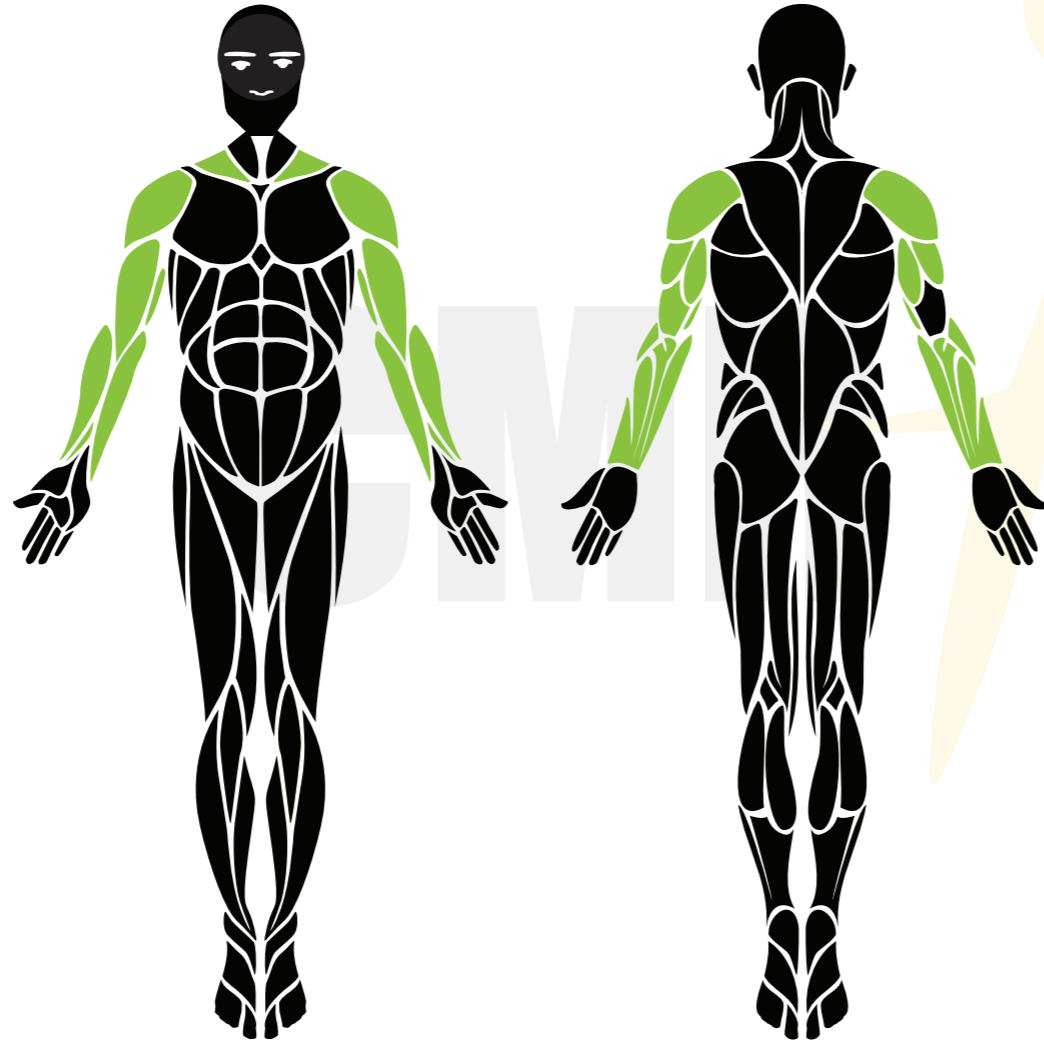

ÜST GÖVDE ESNETME
UPPER BODY STRETCHING

