

X- ERGONOM FITNESS

ACT 212



CMR ACTIVE®

Ürün Bilgisi / Product Information

Boyutlar / Dimensions (LxWxH) : 4,8 x 1,75 x 2,45m



Yaş Grubu / Age Group : ≥140 cm

Kapasitesi / Capacity : 3

Düşme Yüksekliği / Fall Height : 1,4 m

Çalışma Alanı / Training Area : 8,9 m²

Güvenlik Alanı / Safety Area : 30,7 m²

-  **Kardiyo** / Cardio
-  **Isınma** / Warm-up
-  **Güçlenme** / Strength



X - ERGONOM FITNESS / CROSSFIT MULTIPLE TRAINING

Crossfit çoklu antrenman ürünleri, aynı anda birden fazla kişinin kullanımına uygun olarak tasarlanmış olup; çeşitli egzersiz tipine sahiptir. Atletik bir görünüme açık havada antrenman yaparak sahip olabilmek ve fiziksel performansı arttırmak için önemli bir araç niteliğinde olan bu ürünler, aynı zamanda kişilerin sosyalleşmesine ve birbirleriyle iletişim kurma yeteneklerinin artmasına katkı sağlamaktadır.

Crossfit multiple training products are designed to be suitable for many users that work out at the same time and they have many workout options. These products help the users to look more athletic while training outdoors and improve their athletic performance as well as their social skills while interacting with each other.

X- ERGONOM FITNESS

ACT 212



Metal parts are comprised of ST 37 Steel with a 3-step metal finish. Sandblasting and solvent-free zinc primer coating and electrostatic powder paint application is inherently corrosion resistant under extreme weather conditions and UV.

Metal parçalar, 3 aşamalı metal kaplamalı ST 37 çelikten oluşur. Kumlama ve solvent içermeyen çinko astar kaplama ve elektrostatik toz boya uygulaması, aşırı hava koşulları ve UV altında olarak korozyona dayanıklıdır.



Exercise panels are made of 12mm HPL panels with high UV resistant and fire retardant. To increase exercise comfort, HPL minimize the generation of electrostatic charge by contact-separation or rubbing with another material.

12mm HPL plakadan imal edilen egzersiz panelleri; yüksek UV dayanımına ve alev geciktirme özelliğine sahiptir. HPL malzeme; temas ve sürtünme ile oluşan elektrostatik yükü en aza indirerek antrenman konforunu yükseltir.



Polyethylene injection molded anchorage covers are used to seal the metal anchors and provide a nicer look.

Enjeksiyon kalıp tekniğiyle polietilen malzemedен üretilen ankraj kapakları ile metal ayaklar kapatılmakta ve tasarımı tamamlanmaktadır.



CmrRope™ is formed by 6 strands of galvanized wires and a core either steel or fiber. Each strand is tightly braided with Polyester which is adhered to galvanized wires with a patented method to create a solid surface where polyester meets with wires. So extra protection is achieved against friction and vandalism. Surface is extremely abrasion and UV resistant also fire retardant.

CmrRope™, fiber veya çelikten imal çekirdek üzerine sarılı 6 fitilden oluşur. Her bir fitil de galvanizli çelik tel üzerine patentli metodumuz ile sıkı bir şekilde polyester iplerin örülmesi ile elde edilir. Bu üretim tekniği sayesinde sürtünme ve vandalizme karşı ilave dayanıklılık sağlanır. Halat yüzeyi aşınma ve UV ışınlarına dayanıklı ve alev geciktirici niteliktedir.



Single-casing aluminum cast connectors are compressed with 300 tons to avoid moving and premature wear. "E (end stop) connector" is shape-ly and pleasant to grip with no sharp angles or edges. These connectors are fastened to main frame either to welded flanges on main frame or with "C" aluminum clamps to main frame.

Tek parça alüminyum döküm konektörler, ipin hareket etmesini ve erken aşınmayı önlemek için 300 ton pres ile sıkıştırılmıştır. "Sonlandırıcı konektör" keskin açılı veya kenarlar bulundurmaz ve iyi bir kavrama sunar. Bu konektörlerin ana çerçeveye bağlantısı kaynaklı flanşlar ya da "C" alüminyum kelepçelerle yapılır.

X- ERGONOM FITNESS

ACT 212

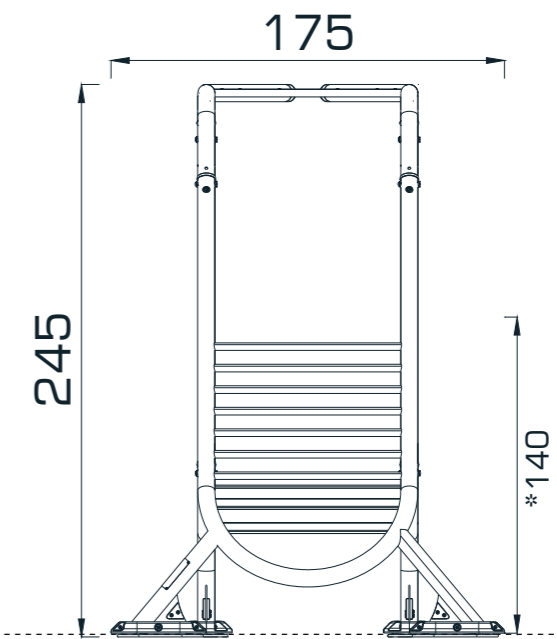
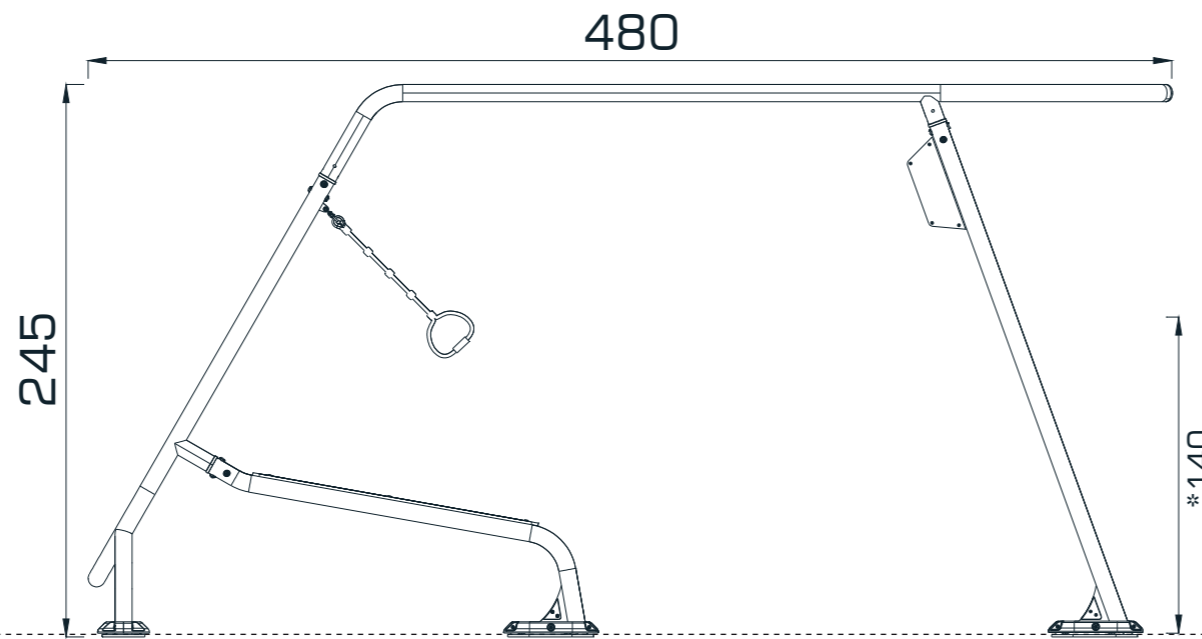
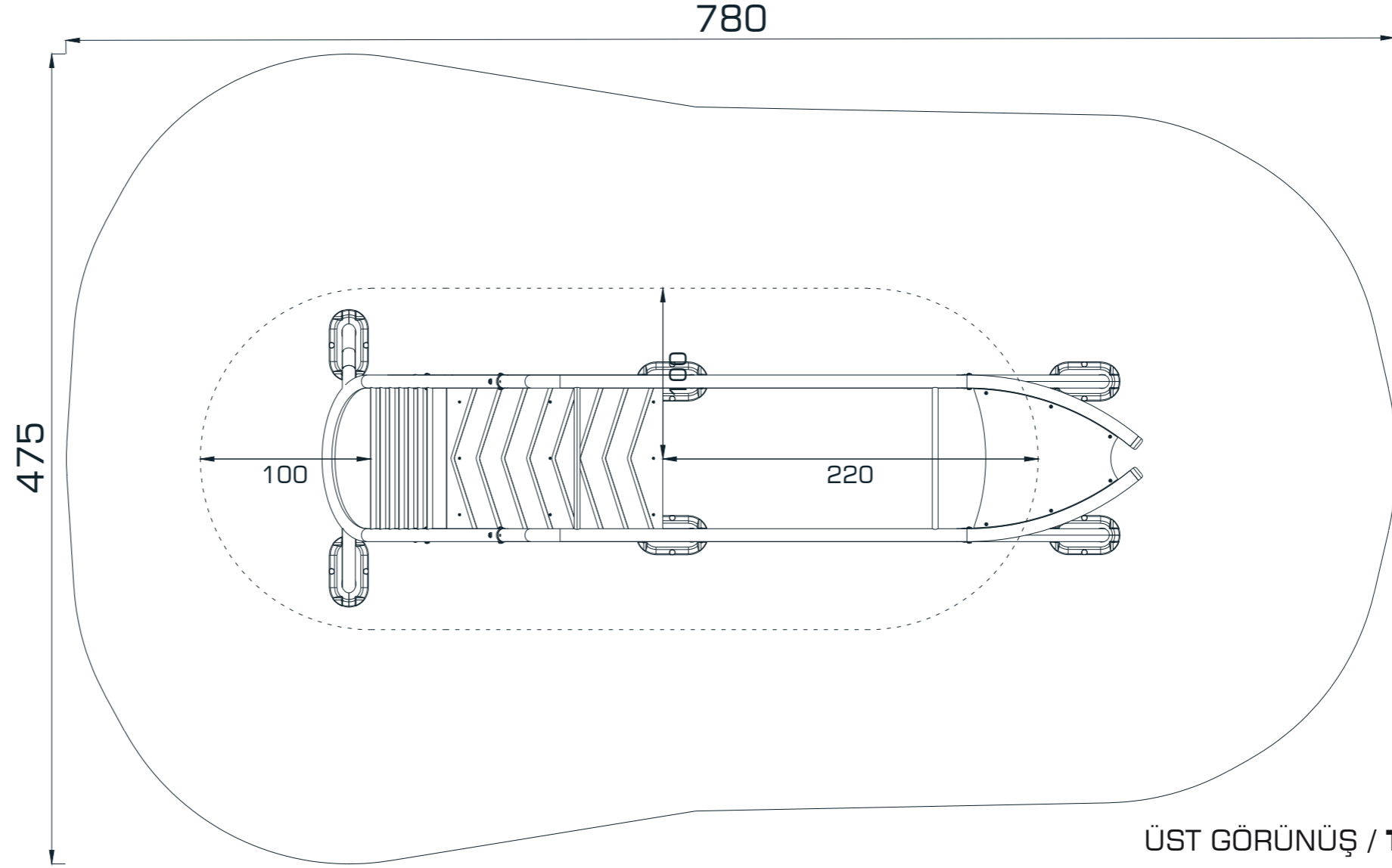

ÖN GÖRÜNÜŞ / FRONT VIEW

Gösterilen ölçüler cm cinsindedir / Dimensions shown are in cm

X- ERGONOM FITNESS

ACT 212

ŞINAV İSTASYONU / PUSH-UP STATION

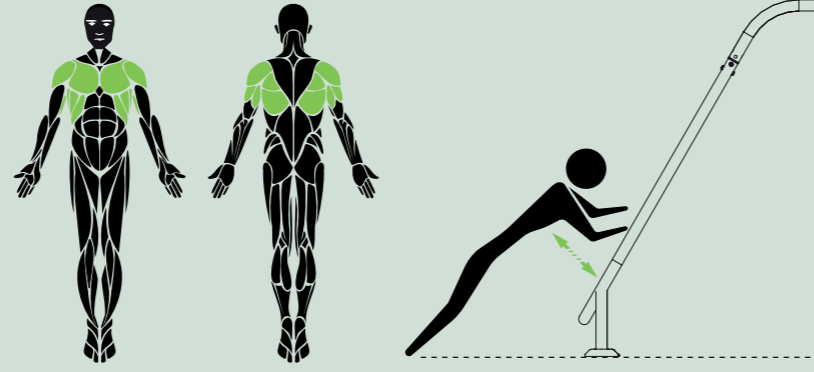

BARFİKS İSTASYONU / PULL-UP STATION

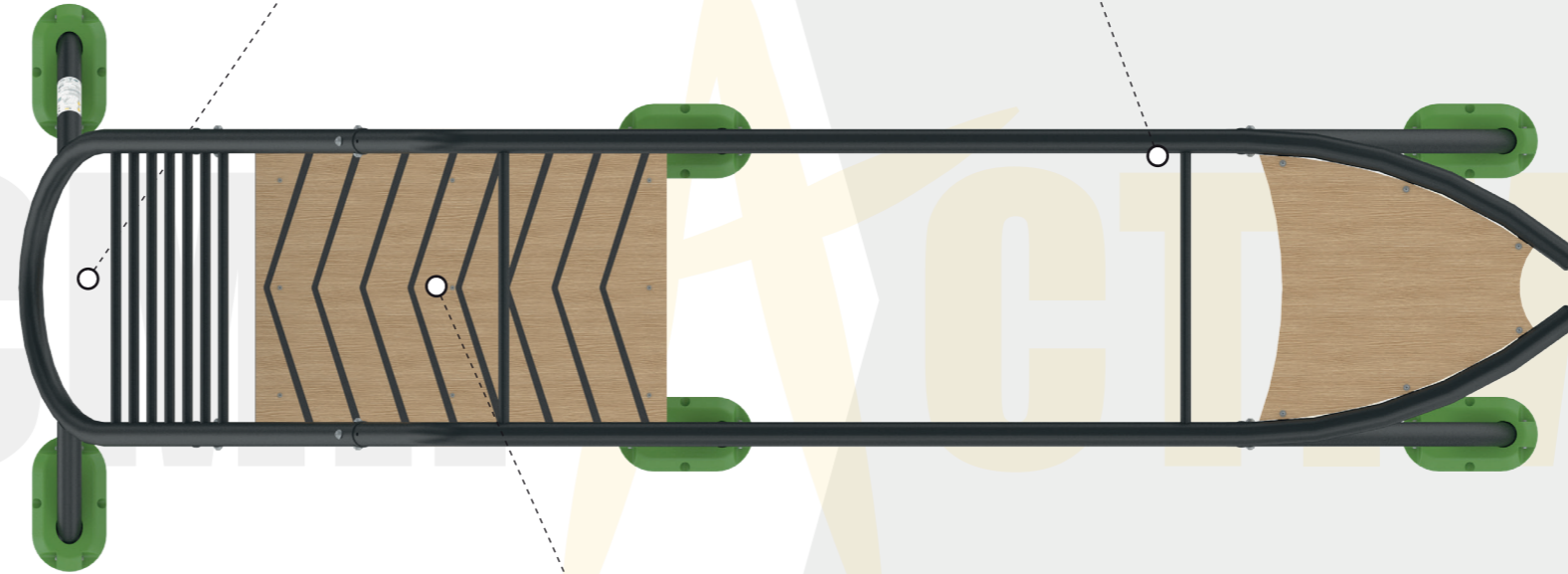
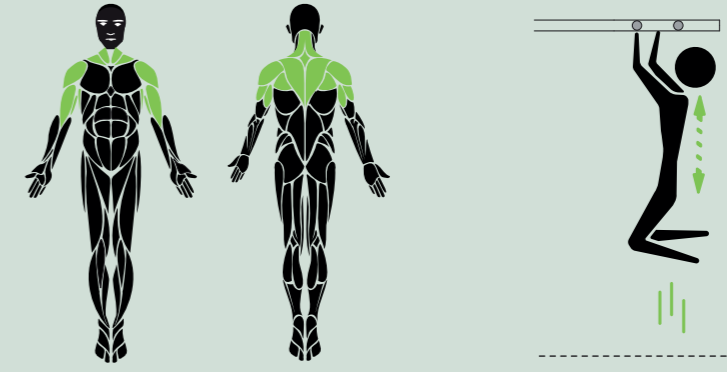

DESTEKLİ YATAY ÇEKME İSTASYONU /
EASY HORIZONTAL PULL STATION

